



PERFORMANCE RANGE

- Flow rate up to **90 l/min** (5.4 m³/h)
- Head up to **100 m**

APPLICATION LIMITS

- Manometric suction lift up to **8 m**
- Liquid temperature between **-10 °C** and **+90 °C**
- Ambient temperature between **-10 °C** and **+40 °C**
(**+50 °C** for PQ 60 and PQ61)
- Max. working pressure:
 - **6 bar** for PQ 60, PQ 61, PQ 65
 - **7 bar** for PQ 70, PQ 80
 - **10 bar** for PQ 90, PQ 100, PQ 200, PQ 300
- Continuous service **S1**

CONSTRUCTION AND SAFETY STANDARDS

EN 60335-1
IEC 60335-1
CEI 61-150

EN 60034-1
IEC 60034-1
CEI 2-3



CERTIFICATIONS

Company with management system
certified DNV
ISO 9001: QUALITY



INSTALLATION AND USE

Suitable for use with clean water that does not contain abrasive particles and with liquids that are not chemically aggressive towards the materials from which the pump is made.

The hydraulic characteristics of these pumps, coupled with their compactness, makes them suitable for use in both domestic and industrial applications.

Installation needs to be undertaken in well ventilated closed areas or anyway protected from bad weather.

PATENTS - TRADE MARKS - MODELS

- Motor bracket: patent n. IT1243605
- Shaft: patent n 0000275945 (PQ60, PQ61, PQ65)
- Registered EU Design n. 002146548
- **PQm 60**® Registered Trade Mark n. 0001520591

OPTIONS AVAILABLE ON REQUEST

- Special mechanical seal
- Other voltages or 60 Hz frequency
- EN 10088-3 - 1.4401 (AISI 316) stainless steel pump shaft for PQ61
- IP X5 class protection for PQ 70-80-90-100-200-300

CHARACTERISTIC CURVES AND PERFORMANCE DATA

50 Hz n = 2900 min⁻¹ HS = 0 m

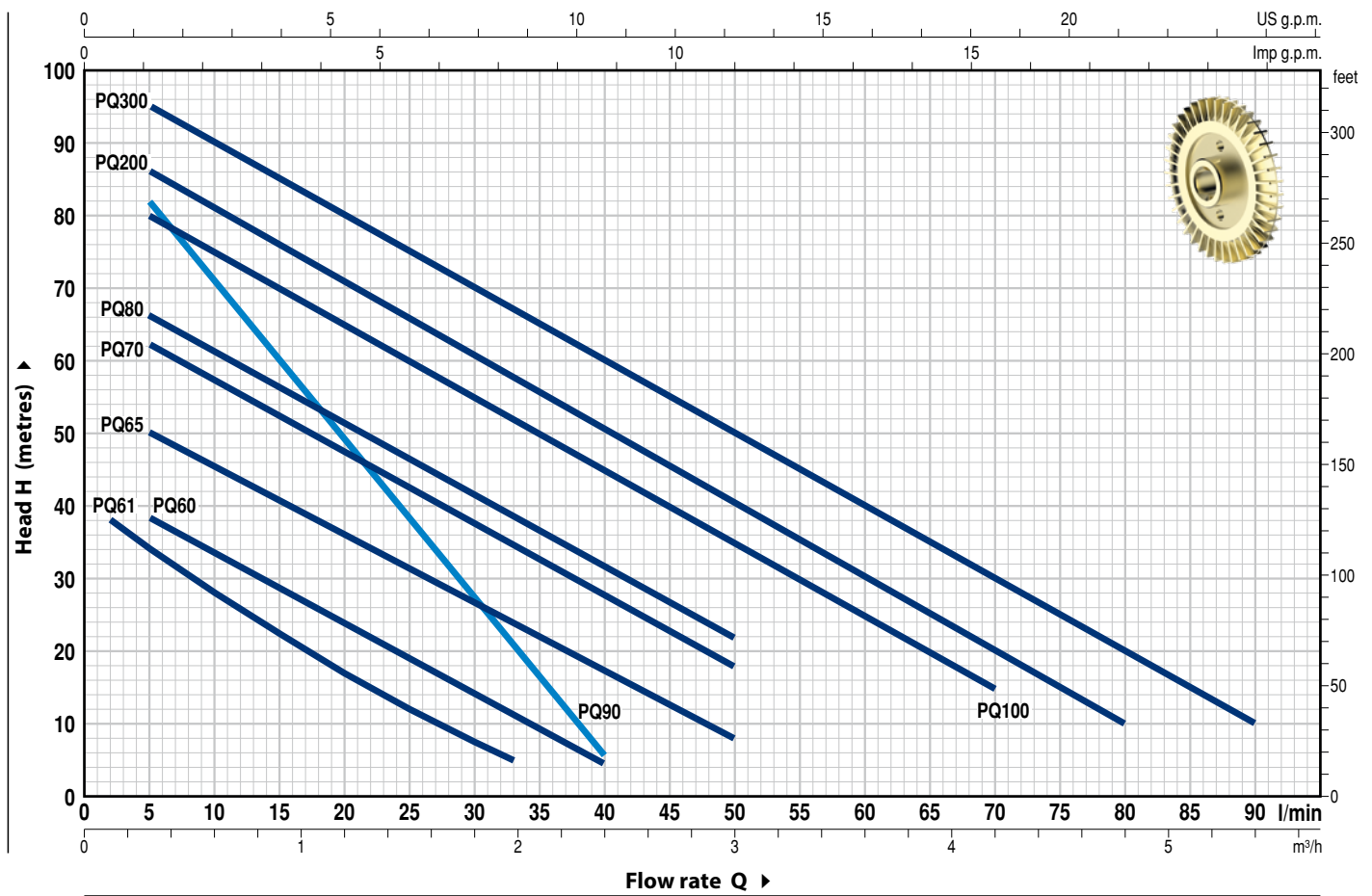

MODEL		POWER (P ₂)			Q	H metres																		
Single-phase	Three-phase	kW	HP	▲		m ³ /h	0	0.12	0.3	0.6	0.9	1.2	1.5	1.8	1.98	2.1	2.4	3.0	3.6	4.2	4.8	5.4		
					l/min	0	2	5	10	15	20	25	30	33	35	40	50	60	70	80	90			
PQm 60	PQ 60	0.37	0.50	IE2	H metres	40	-	38	33.5	29	24	19.5	15	11	10	5								
PQm 61	PQ 61	0.37	0.50			40.5	38	34	28	22.3	17	12.1	7.5	5										
PQm 65	PQ 65	0.55	0.75			55	-	50	45.5	40.5	36	31	27	24	22	17	8							
PQm 70	PQ 70	0.60	0.85	65		-	62	57	52	47	42	37	35	32	27	18								
PQm 80	PQ 80	0.75	1	70		-	66	61	56	51	46	41	38.5	36.5	31	22								
PQm 90	PQ 90	0.75	1	IE3		90	-	82	71	60	49	38	27	21	17	5								
PQm 100	PQ 100	1.1	1.5			85	-	80	75	70	65	60	55	52	50	45	35	25	15					
PQm 200	PQ 200	1.5	2			90	-	86	81	76	71	65.5	60	58	55	50	40	30	20	10				
PQm 300	PQ 300	2.2	3			100	-	95	90	85	80	75	70	67	65	60	50	40	30	20	10			

Q = Flow rate H = Total manometric head HS = Suction height

Tolerance of characteristic curves in compliance with EN ISO 9906 Grade 3B.

▲ Three-phase motor efficiency class (IEC 60034-30-1)

POS. COMPONENT CONSTRUCTION CHARACTERISTICS

1	PUMP BODY	Cast iron with threaded ports in compliance with ISO 228/1 Cast iron with threaded ports in compliance with ISO 228/1 for PQ 61				
2	MOTOR BRACKET	Aluminium with brass insert (patented), reduces the risk of impeller seizure				
3	IMPELLER	Brass with peripheral radial vanes				
4	MOTOR SHAFT	Stainless steel AISI 431 (EN 10088-3 - 1.4104 for PQ 60, PQ 61, PQ 65)				
5	MECHANICAL SEAL	<i>Pump</i>	<i>Seal</i>	<i>Shaft</i>	<i>Materials</i>	
		<i>Model</i>	<i>Model</i>	<i>Diameter</i>	<i>Stationary ring</i>	<i>Rotational ring</i>
		PQ 60-61-65-70-80	AR-12	Ø 12 mm	Ceramic	Graphite
		PQ 90	ST1-12	Ø 12 mm	Silicon carbide	Graphite
		PQ 100-200-300	FN-14	Ø 14 mm	Graphite	Ceramic
6	BEARINGS	<i>Pump</i>	<i>Model</i>			
		PQ 60-61-65	6201 ZZ / 6201 ZZ			
		PQ 70-80-90	6203 ZZ / 6203 ZZ			
		PQ 100-200-300	6204 ZZ / 6204 ZZ			
7	CAPACITOR					
8	ELECTRIC MOTOR	<p>PQm: single-phase 230 V - 50 Hz with thermal overload protector incorporated into the winding. PQ: three-phase 230/400 V - 50 Hz.</p> <p>⇒ The three-phase pumps are fitted with high performance motors up to P₂=0.55 kW in class IE2 and from P₂=0.60 kW in class IE3 (IEC 60034-30-1)</p> <ul style="list-style-type: none"> - Insulation: class F - Protection: IP X4 				

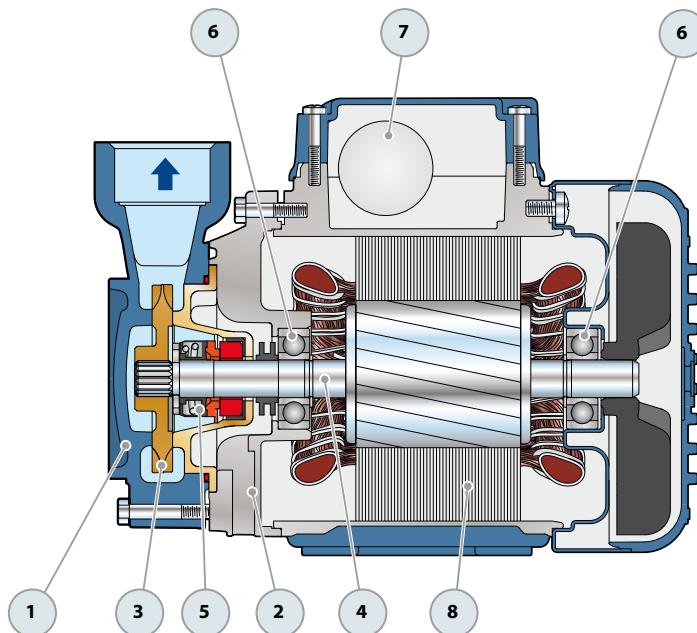

DIMENSIONS AND WEIGHT

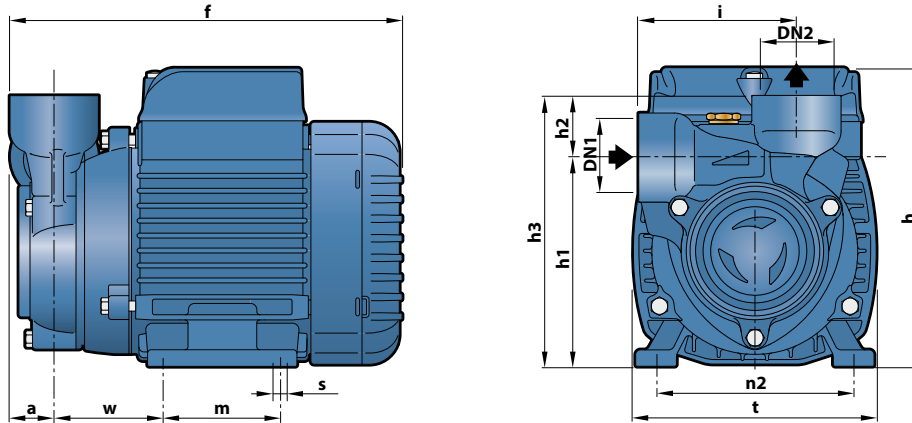

MODEL		PORTS		DIMENSIONS mm													kg	
Single-phase	Three-phase	DN1	DN2	a	f	h	h1	h2	h3	i	m	t	n2	w	s	1~	3~	
PQm 60	PQ 60	1"	1"	22	192	145	101	30	131	76	55	118	94-100	53	7	4.8	4.8	
PQm 61	PQ 61	½"	½"	21	191			32.5	133.5	75.5						4.9	4.9	
PQm 65	PQ 65	1"	1"	22	220	152	113	30	143	78	80	120	100	62.5	7	6.9	6.2	
PQm 70	PQ 70				256	181 *	121		151	83	90	142	112			9.7	9.8	
PQm 80	PQ 80	¾"	¾"	22	256	181 *	126	27	153	84	90	142	112	62.5	7	9.7	9.7	
PQm 90	PQ 90															9.9	8.9	
PQm 100	PQ 100	1"	1"	29	322.5	211	140	28	168	88	100	164	125	95	9	14.1	14.0	
PQm 200	PQ 200				342.5											15.2	15.2	
PQm 300	PQ 300				—											17.8		

(*) h=199 mm for single-phase versions at 110 V

ABSORPTION AND CAPACITORS

MODEL	VOLTAGE			CAPACITANCE	
	230 V	240 V	110 V	(230 V or 240 V)	(110 V)
PQm 60	2.6 A	2.4 A	5.2 A	10 µF - 450 VL	25 µF - 250 VL
PQm 61	2.3 A	2.2 A	4.6 A	10 µF - 450 VL	25 µF - 250 VL
PQm 65	3.7 A	3.5 A	7.4 A	14 µF - 450 VL	25 µF - 250 VL
PQm 70	5.2 A	4.8 A	10.4 A	16 µF - 450 VL	60 µF - 300 VL
PQm 80	5.2 A	5.0 A	10.5 A	20 µF - 450 VL	60 µF - 300 VL
PQm 90	5.6 A	5.1 A	11.5 A	20 µF - 450 VL	60 µF - 300 VL
PQm 100	9.0 A	8.6 A	18.0 A	31.5 µF - 450 VL	60 µF - 250 VL
PQm 200	12.0 A	11.5 A	24.0 A	45 µF - 450 VL	80 µF - 250 VL
PQm 300	13.0 A	12.5 A	—	50 µF - 450 VL	—

MODEL	VOLTAGE				
	230 V	400 V	690 V	240 V	415 V
PQ 60	2.0 A	1.15 A	0.7 A	1.9 A	1.1 A
PQ 61	2.0 A	1.15 A	0.7 A	1.9 A	1.1 A
PQ 65	3.0 A	1.7 A	1.0 A	2.8 A	1.6 A
PQ 70	3.8 A	2.2 A	1.3 A	3.3 A	1.9 A
PQ 80	3.8 A	2.2 A	1.3 A	3.6 A	2.1 A
PQ 90	4.2 A	2.4 A	1.4 A	3.8 A	2.2 A
PQ 100	6.2 A	3.6 A	2.1 A	5.9 A	3.4 A
PQ 200	8.3 A	4.8 A	2.8 A	7.9 A	4.6 A
PQ 300	9.0 A	5.2 A	3.0 A	8.7 A	5.0 A

PALLETIZATION

MODEL		GROUPAGE	CONTAINER
Single-phase	Three-phase	n. pumps	n. pumps
PQm 60	PQ 60	256	352
PQm 61	PQ 61	238	306
PQm 65	PQ 65	210	270
PQm 70	PQ 70	102	170
PQm 80	PQ 80	102	170
PQm 90	PQ 90	102	170
PQm 100	PQ 100	72	96
PQm 200	PQ 200	72	96
PQm 300	PQ 300	72	270