

Submersible pumps

-  Sewage water
-  Domestic use
-  Civil use
-  Industrial use



PERFORMANCE RANGE

- Flow rate up to **850 l/min** (51 m³/h)
- Head up to **17 m**

APPLICATION LIMITS

- **5 m** maximum immersion depth (with a sufficiently long power cable)
- Maximum liquid temperature **+40 °C**
- Passage of suspended solids up to **Ø 50 mm**
- Minimum immersion depth for continuous service:
 - **290 mm** for BC 10/50
 - **330 mm** for BC 15/50
 - **360 mm** for BC 20/50

CONSTRUCTION AND SAFETY STANDARDS

- Power cable length:
 - **5 m** for BC 10/50
 - **10 m** for BC 15/50, BC 20/50,
- Float switch for single-phase versions

EN 60335-1
IEC 60335-1
CEI 61-150

EN 60034-1
IEC 60034-1
CEI 2-3



INSTALLATION AND USE

BC submersible pumps are suitable for draining **dirty and sewage water** in domestic and civil applications. They come equipped with a DOUBLE-CHANNEL stainless steel impeller and are capable of pumping liquids containing short fibred suspended solids up to Ø 50 mm.

They are ideal for pumping sewage, waste water, surface water and water mixed with mud in locations such as blocks of flats and detached houses.

These pumps distinguish themselves for their reliability, which can be best appreciated under automatic operating conditions in fixed installations.

PATENTS - TRADE MARKS - MODELS

- Patent n. EP2313658
- Patent n. IT0001428923

OPTIONS AVAILABLE ON REQUEST

- BC10/50 pumps with a **10 m** power cable.
 - ➔ N.B.: Standard EN 60335-2-41 states that the power cable must be 10 m long for outdoor applications
- Single-phase pumps without float switch
- Other voltages or 60 Hz frequency

CERTIFICATIONS

Company with management system certified DNV ISO 9001: QUALITY



CHARACTERISTIC CURVES AND PERFORMANCE DATA

50 Hz n= 2900 min⁻¹

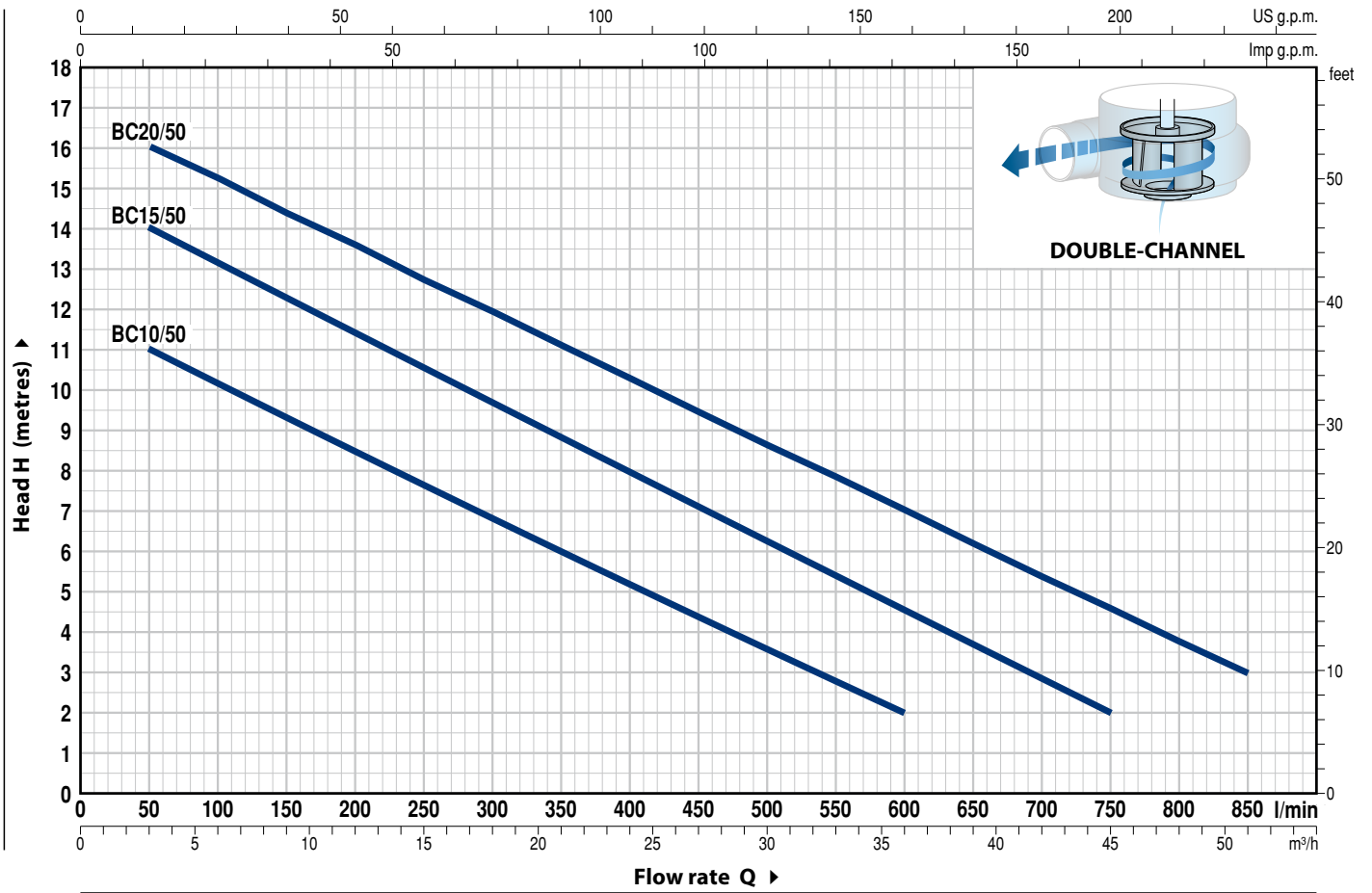

| MODEL | | POWER (P ₂) | | Q | Flow rate | | | | | | | | | | | | | | |
|--------------|-------------|-------------------------|-----|----------|-------------------|----|------|------|-----|------|-----|-----|-----|-----|-----|----|--|--|--|
| Single-phase | Three-phase | kW | HP | | m ³ /h | 0 | 3 | 6 | 12 | 18 | 24 | 30 | 36 | 42 | 45 | 51 | | | |
| | | | | l/min | 0 | 50 | 100 | 200 | 300 | 400 | 500 | 600 | 700 | 750 | 850 | | | | |
| BCm 10/50 | BC 10/50 | 0.75 | 1 | H metres | 12 | 11 | 10 | 8.5 | 7 | 5 | 3.6 | 2 | | | | | | | |
| BCm 15/50 | BC 15/50 | 1.1 | 1.5 | | 15 | 14 | 13 | 11.5 | 9.7 | 8 | 6.3 | 4.6 | 2.9 | 2 | | | | | |
| BCm 20/50 | BC 20/50 | 1.5 | 2 | | 17 | 16 | 15.3 | 13.5 | 12 | 10.3 | 8.6 | 7.0 | 5.3 | 4.5 | 3 | | | | |

Q = Flow rate H = Total manometric head

Tolerance of characteristic curves in compliance with EN ISO 9906 Grade 3B.

POS. COMPONENT CONSTRUCTION CHARACTERISTICS

| | |
|-----------------------------|--|
| 1 PUMP BODY | Cast iron with an Epoxy Electro Coating treatment for a greater resistance to corrosion, with threaded port in compliance with ISO 228/1 |
| 2 BASE | Stainless steel AISI 304 |
| 3 IMPELLER | DOUBLE CHANNEL type AISI 304 micro-cast stainless steel. The DOUBLE CHANNEL impeller permits one to obtain an excellent performance and a high energy efficiency, developing a greater pressure and guaranteeing the pumping of solid bodies with a diameter of up to 50 mm. Undoubtedly the best solution for the drainage of waste water. |
| 4 MOTOR CASING | Stainless steel AISI 304 |
| 5 MOTOR CASING PLATE | Stainless steel AISI 304 for BC 10/50 Cast iron with an Epoxy Electro Coating treatment for BC 15/50, BC 20/50 |
| 6 MOTOR SHAFT | Stainless steel AISI 431 |



7 DOUBLE MECHANICAL SEAL IN OIL CHAMBER

| Seal Model | Shaft Diameter | Position | Materials | | |
|-------------|----------------|------------|-----------------|-----------------|-----------|
| | | | Stationary ring | Rotational ring | Elastomer |
| MG1-14D SIC | Ø 14 mm | Motor side | Silicon carbide | Graphite | NBR |
| | | Pump side | Silicon carbide | Silicon carbide | NBR |

Double mechanical seal with an intermediate oil chamber, with silicon carbide chute slides for a greater resistance to abrasion and wear and for a longer life of the pump.

8 BEARINGS

| Pump | Model |
|--------------------|-------------------------|
| BC 10/50 | 6203 ZZ / 6203 ZZ |
| BC 15/50, BC 20/50 | 6303 2RS - C3 / 6203 ZZ |

9 CAPACITOR EN 60252-1/A1  
(only for single-phase versions)

10 ELECTRIC MOTOR

Electric motors produced to a high quality standard, subjected to the most rigorous checks to ensure excellent insulation. The impregnation of the winding, achieved with high quality resins, is followed by treatment in an oven for up to eight hours, thus ensuring the long working life of the motor.

BCm: single-phase 230 V - 50 Hz
with thermal overload protector incorporated into the winding
BC: three-phase 400 V - 50 Hz
– Insulation: class F
– Protection: IP X8

11 POWER CABLE

Power cable encapsulated in epoxy resin both in the area of the grommets and at the point where the wires exit the sheath, resulting in an absolute insulation from moisture and water infiltration.

H07 RN-F" type
(with Schuko plug for single-phase versions only)

Standard length:

- 5 metri for BC 10/50,
- 10 metri for BC 15/50, BC 20/50

12 FLOAT SWITCH

(only for single-phase versions)

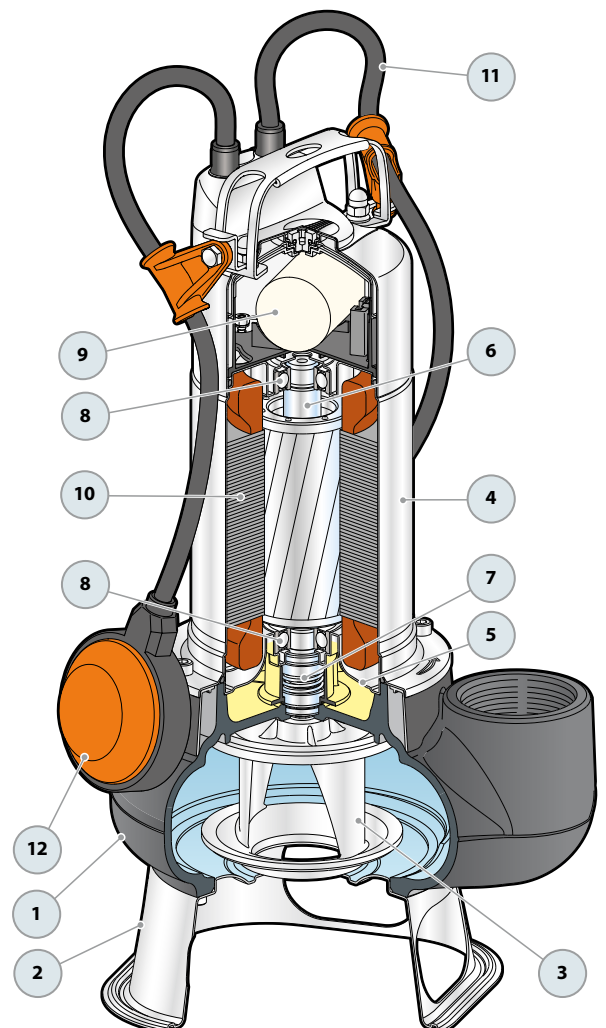

DIMENSIONS AND WEIGHT

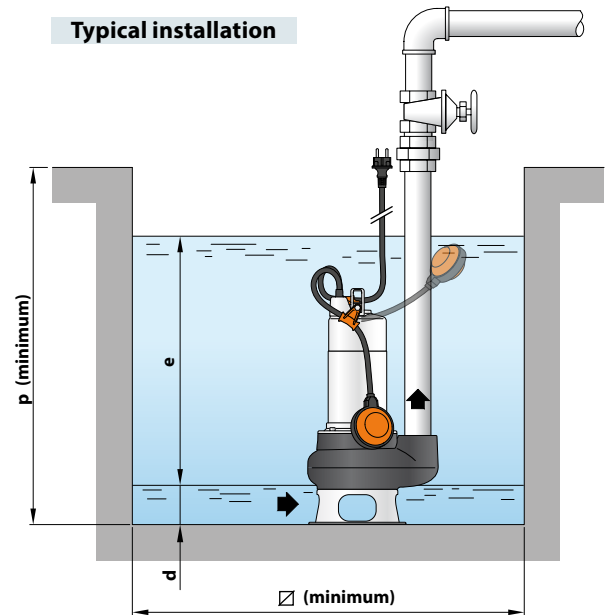
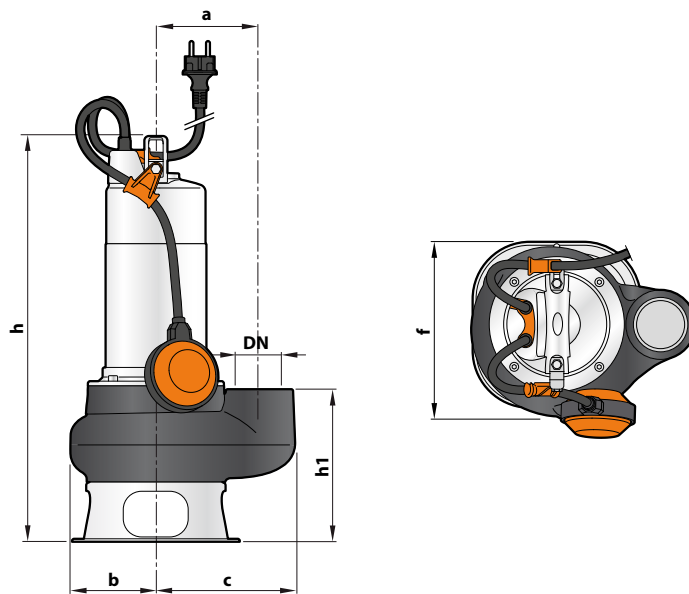

| MODEL | | PORT DN | Passage of solids | DIMENSIONS mm | | | | | | | | | | kg | |
|--------------|-------------|------------|----------------------|---------------|----|-----|-----|-----|-----|----|----------|-----|-----|------|------|
| Single-phase | Three-phase | | | a | b | c | f | h | h1 | d | e | p | Ø | 1~ | 3~ |
| BCm 10/50 | BC 10/50 | 2" | Ø 50 mm | 115 | 95 | 155 | 200 | 451 | 169 | 60 | variable | 500 | 500 | 16.2 | 15.0 |
| BCm 15/50 | BC 15/50 | | | | | | | 484 | | | | | | 18.8 | 17.2 |
| BCm 20/50 | BC 20/50 | | | | | | | 514 | | | | | | 21.0 | 18.8 |

ABSORPTION

| MODEL | VOLTAGE | |
|--------------|---------|-------|
| Single-phase | 230 V | 240 V |
| BCm 10/50 | 5.5 A | 5.4 A |
| BCm 15/50 | 8.0 A | 7.8 A |
| BCm 20/50 | 10.0 A | 9.8 A |

| MODEL | VOLTAGE | | | |
|-------------|---------|-------|-------|-------|
| Three-phase | 230 V | 400 V | 240 V | 415 V |
| BC 10/50 | 3.8 A | 2.2 A | 3.6 A | 2.1 A |
| BC 15/50 | 5.3 A | 3.1 A | 5.1 A | 2.9 A |
| BC 20/50 | 6.7 A | 3.9 A | 6.5 A | 3.7 A |

CAPACITORS

| MODEL | CAPACITANCE |
|--------------|------------------|
| Single-phase | (230 V or 240 V) |
| BCm 10/50 | 25 µF 450 VL |
| BCm 15/50 | 35 µF 450 VL |
| BCm 20/50 | 35 µF 450 VL |

PALLETIZATION

| MODEL | | GROUPAGE | CONTAINER |
|--------------|-------------|----------|-----------|
| Single-phase | Three-phase | n. pumps | n. pumps |
| BCm 10/50 | BC 10/50 | 45 | 60 |
| BCm 15/50 | BC 15/50 | 30 | 45 |
| BCm 20/50 | BC 20/50 | 30 | 45 |