

-  Dirty water
-  Domestic use
-  Civil use

※ All stainless steel pumps



PERFORMANCE RANGE

- Flow rate up to **380 l/min** (22.8 m³/h)
- Head up to **12.8 m**

INSTALLATION AND USE

RX-VORTEX pumps excel in draining **dirty water**, featuring designs that ensure reliable performance even during continuous operation, thanks to comprehensive motor cooling. Ideal for **domestic, civil, and industrial applications**, these pumps are perfect for removing dirty water containing suspended solids.

APPLICATION LIMITS

- Maximum operating depth below water level up to **10 m** (with an appropriately sized power cable)
- Liquid temperature up to **+50 °C** and up to **+90 °C** for short bursts (up to 3 minutes max) for intermittent service
- Suspended solids transfer:
 - up to **Ø 20 mm** for RX 2/20, RX 3/20
 - up to **Ø 40 mm** for RX 4/40, RX 5/40
- Draining capability:
 - up to **25 mm** from the bottom for RX 2/20, RX 3/20
 - up to **50 mm** from the bottom for RX 4/40, RX 5/40

PATENTS - TRADE MARKS - MODELS

- Patent No. EP2313658
- Patent No. IT0001428923

INCLUDES

- ※ Power cable length **5 m**
- ※ Float switch for single-phase versions

AVAILABLE UPON REQUEST

- ※ Mechanical seal options available
- ※ Pumps with **10 m** power cable.
- ※ Different voltage requirements 60 Hz frequency
- ※ **RX-VORTEX GM** pumps with magnetically operated float switch (suitable for small sumps)



CURVES AND PERFORMANCE DATA

50 Hz

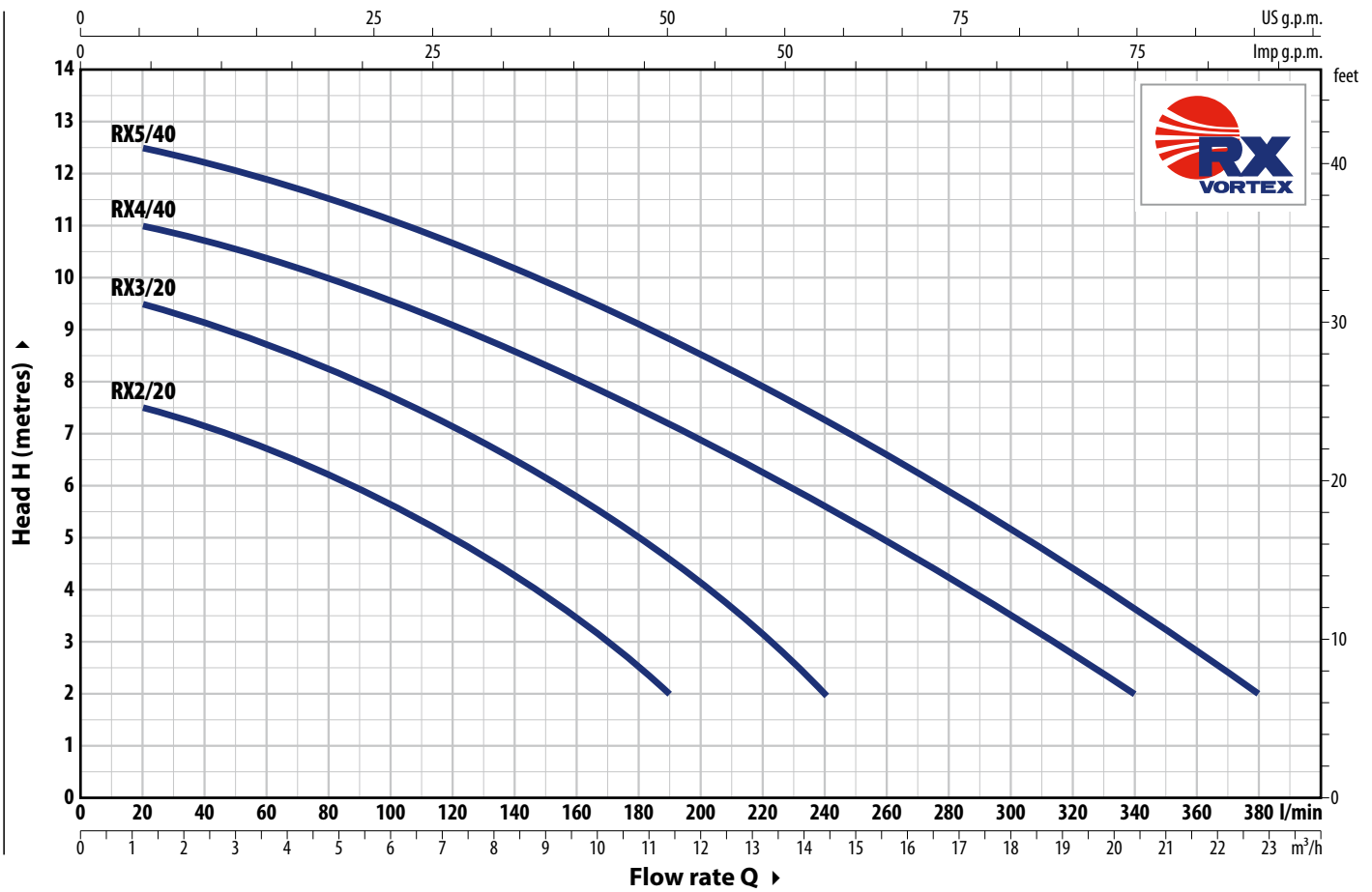

TYPE		POWER (P ₂)		Q	Flow rate (l/min)																
Single-phase	Three-phase	kW	HP		0	1.2	3.6	6.0	7.8	9.6	11.4	12.6	14.4	16.2	18.0	20.4	22.8				
RXm 2/20	RX 2/20	0.37	0.50	H metres	8	7.5	6.7	5.6	4.7	3.5	2										
RXm 3/20	RX 3/20	0.55	0.75		10	9.5	8.7	7.7	6.8	5.8	4.5	3.6	2								
RXm 4/40	RX 4/40	0.75	1		11.3	11	10.3	9.5	8.8	8	7.2	6.6	5.7	4.7	3.6	2					
RXm 5/40	RX 5/40	1.1	1.5		12.8	12.5	11.8	11	10.4	9.7	8.8	8.3	7.3	6.3	5.3	3.7	2				

Q = Flow rate H = Total manometric head

Performance curves comply with EN ISO 9906 Grade 3B tolerance limits.

ABSORPTION

TYPE	VOLTAGE
Single-phase	230 V
RXm 2/20	2.3 A
RXm 3/20	3.4 A
RXm 4/40	5.2 A
RXm 5/40	6.5 A

TYPE	VOLTAGE
Three-phase	400 V
RX 2/20	1.1 A
RX 3/20	1.5 A
RX 4/40	2.1 A
RX 5/40	3.1 A

DIMENSIONS AND WEIGHT

Typical installation

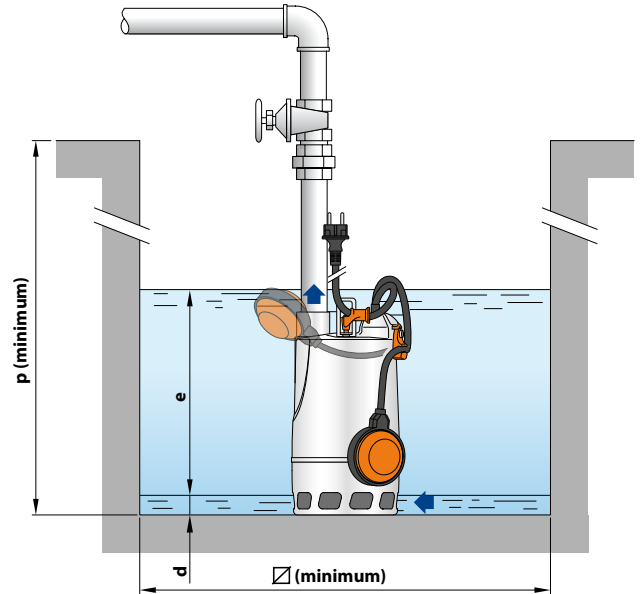
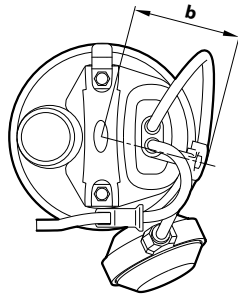
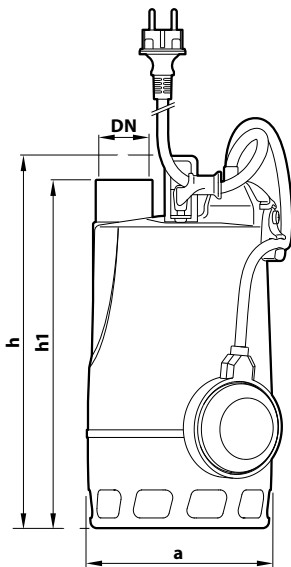

TYPE		PORT DN	DIMENSIONS mm								kg		PALLET CAPACITY
Single-ph.	Three-ph		a	b	h	h1	d	e	p	Ø	1~	3~	
RXm 2/20	RX 2/20	1 1/4"	147	84	300	275	25	adjustable	350	350	6.2	5.8	96
RXm 3/20	RX 3/20				330	305					7.7	7.0	

※ Version with 'GM' magnetic float switch

Typical installation

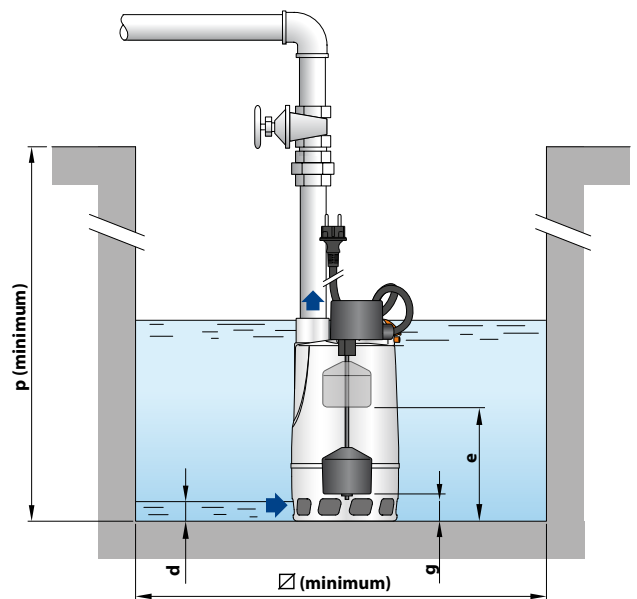
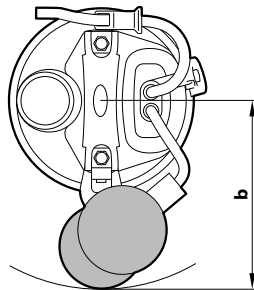
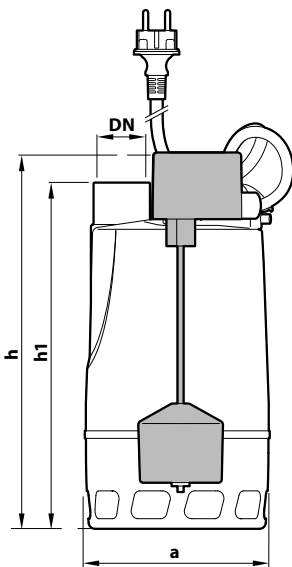

TYPE		PORT DN	DIMENSIONS mm								kg		PALLET CAPACITY
Single-phase			a	b	h	h1	d	e	g (adjustable)	p	Ø	1~	
RXm 2/20-GM	1 1/4"	147	150	302	275	25	180	50	350	240	6.3	80	
RXm 3/20-GM				332	305		210	80			7.9		

MATERIALS AND COMPONENTS

1	Outer sleeve	AISI 304 stainless steel with ISO 228/1 threaded port
2	Suction filter	Stainless steel AISI 304
3	Diffuser	Stainless steel AISI 304
4	Impeller	VORTEX in AISI 304 stainless steel
5	Motor sleeve	Stainless steel AISI 304
6	Motor cover	Stainless steel AISI 304
7	Motor shaft	Stainless steel AISI 431
8	Double shaft seal with interposed oil chamber	
	Seal	Shaft
	STA-12R SIC	Ø 12 mm
		Materials
		Ceramic / Silicon carbide / NBR
	Shaft seal	Ø 12 x Ø 19 x H 5 mm

9 **Capacitor**
(exclusive to single-phase models)

10 Electric motor

- RXm:** single-phase 230 V - 50 Hz with winding integrated thermal motor protection
RX: three-phase 400 V - 50 Hz
 – Continuous running duty S1
 – Insulation: Class F
 – Protection rating IP X8

11 Power cord

- Type 'H07 RN-F'
 (Schuko plug exclusive to single-phase models)
 ※ Standard length 5 metres

12 Float switch

- (exclusive to single-phase models)

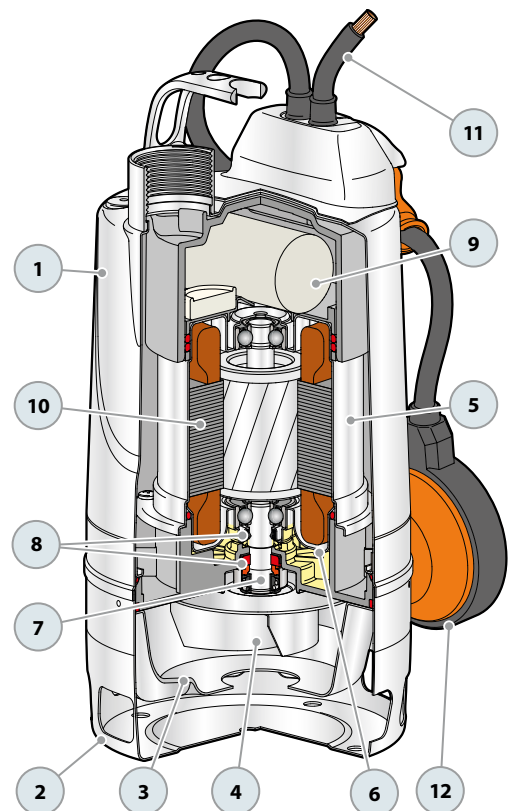

DIMENSIONS AND WEIGHT

Typical installation

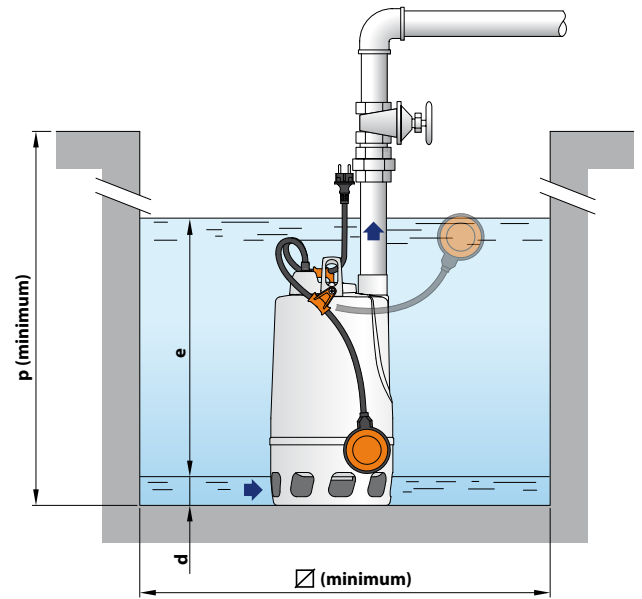
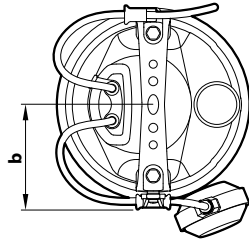
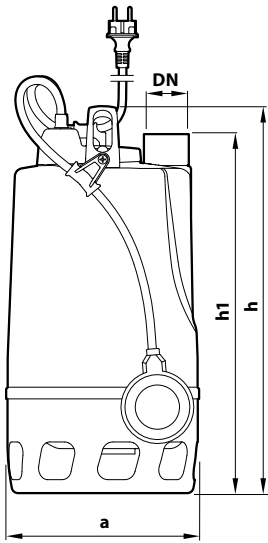

TYPE		PORT DN	DIMENSIONS mm								kg		PALLET CAPACITY
Single-phase	Three-phase		a	b	h	h1	d	e	p	∅	1~	3~	
RXm 4/40	RX 4/40	1½"	215	115	432	400	50	adjustable	500	500	14.8	13.9	45
RXm 5/40	RX 5/40										16.0	14.8	45

※ Version with 'GM' magnetic float switch

Typical installation

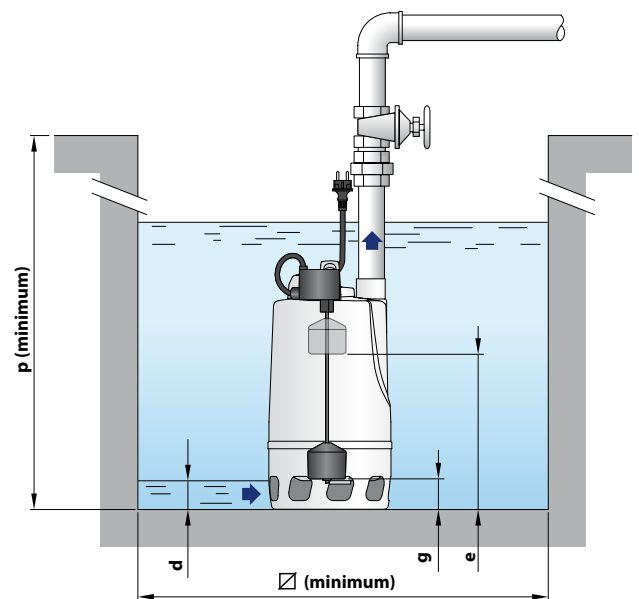
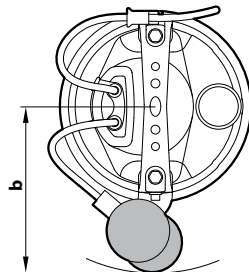
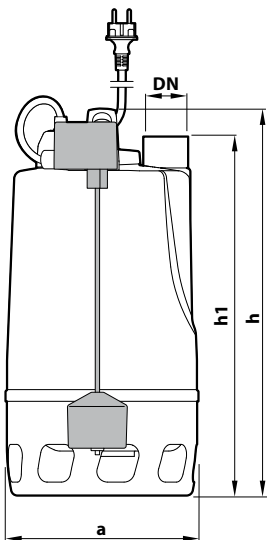

TYPE		PORT DN	DIMENSIONS mm								kg		PALLET CAPACITY
Single-phase			a	b	h	h1	d	e	g (adjustable)	p	∅	1~	
RXm 4/40 - GM		1½"	215	186.5	432	400	50	320	80	500	350	15.2	36
RXm 5/40 - GM												16.2	36

MATERIALS AND COMPONENTS

1 Outer sleeve	AISI 304 stainless steel with ISO 228/1 threaded port		
2 Suction filter	Stainless steel AISI 304		
3 Diffuser	Stainless steel AISI 304		
4 Impeller	VORTEX in AISI 304 stainless steel		
5 Motor sleeve	Stainless steel AISI 304		
6 Motor cover	Stainless steel AISI 304		
7 Motor shaft	Stainless steel AISI 431		
8 Double mechanical seal with interposed oil chamber			
Seal	Shaft	Location	Materials
MG1-14D SIC Ø 14 mm		Motor side	Silicon carbide / Graphite / NBR
		Pump side	Silicon carbide/Silicon carbide/NBR

9 Capacitor
(exclusive to single-phase models)

10 Electric motor

RXm: single-phase 230 V - 50 Hz with winding integrated thermal motor protection

RX: three-phase 400 V - 50 Hz

- Continuous running duty S1
- Insulation: Class F
- Protection rating IP X8

11 Power cord

Type 'H07 RN-F
(Schuko plug exclusive to single-phase models)

※ Standard length 5 metres

12 Float switch
(exclusive to single-phase models)

