

## Standardised “EN 733” centrifugal pumps

 Clean water

 Industrial use



### PERFORMANCE RANGE

- Flow rate up to **3000 l/min** (180 m<sup>3</sup>/h)
- Head up to **24 m**

### APPLICATION LIMITS

- Manometric suction lift up to **7 m**
- Liquid temperature between **-10 °C** and **+90 °C**
- Ambient temperature between **-10 °C** and **+40 °C**
- Max. pressure in pump body **10 bar** (PN10)
- Continuous service **S1**

### CONSTRUCTION AND SAFETY STANDARDS

EN 60335-1  
IEC 60335-1  
CEI 61-150

EN 60034-1  
IEC 60034-1  
CEI 2-3



Pump body dimensions in compliance with **EN 733**  
**EU REGULATION N. 547/2012**

### CERTIFICATIONS

Company with management system certified DNV  
ISO 9001: QUALITY



### INSTALLATION AND USE

- Water supply
- Pressure boosting
- Irrigation
- Water circulation in air-conditioning units
- Cleaning sets
- Firefighting sets
- Industrial applications
- Agricultural applications

Installation needs to be undertaken in well ventilated closed areas or anyway protected from bad weather.

### OPTIONS AVAILABLE ON REQUEST

- Counter flange KIT complete with bolts, nuts and washers
- Other voltages or 60 Hz frequency
- Compatibility with hotter or colder liquids
- Compatibility with hotter or colder environments

## PERFORMANCE RANGE

50 Hz n = 1450 min<sup>-1</sup>

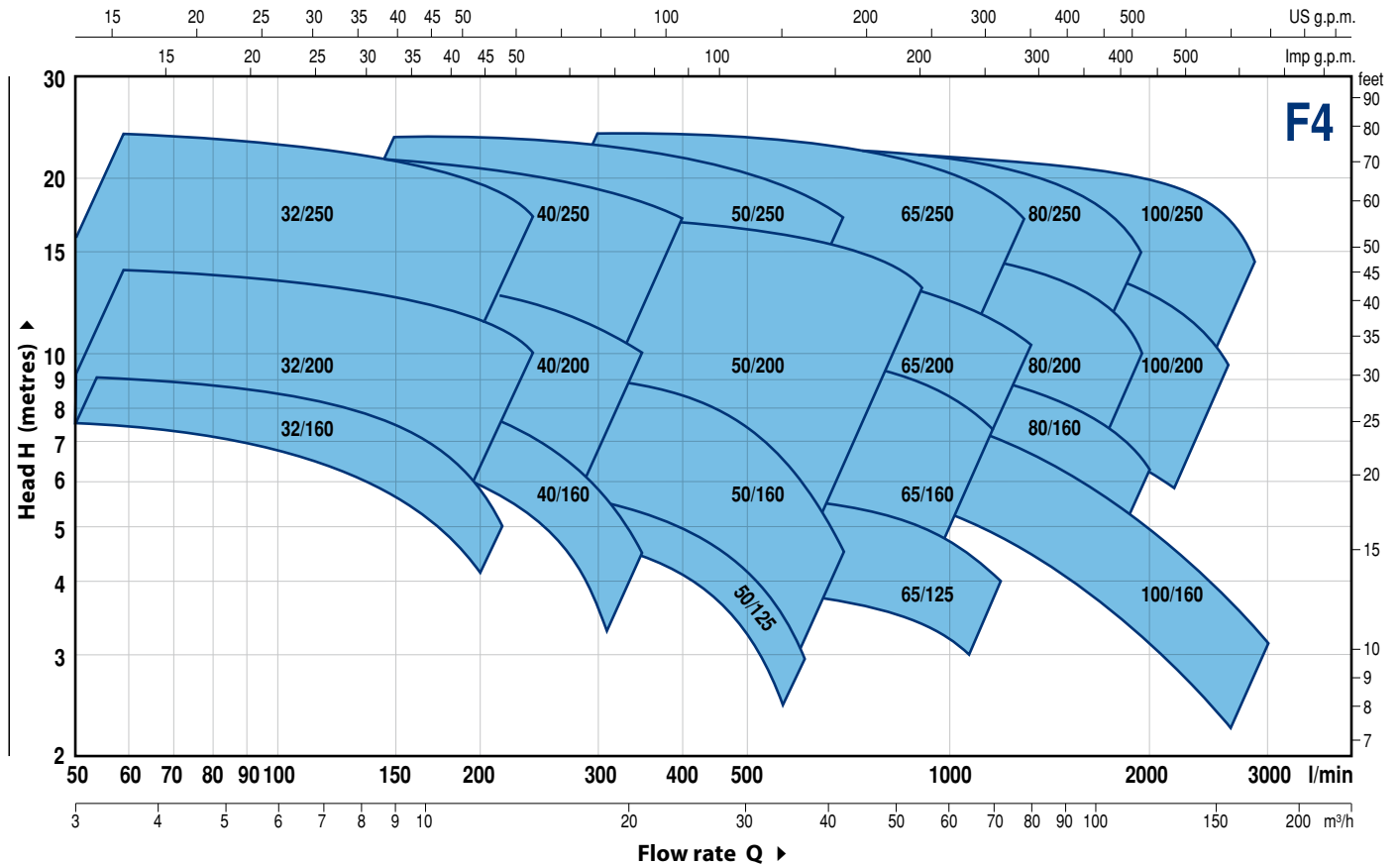

## PERFORMANCE DATA

50 Hz n = 1450 min<sup>-1</sup>

MODEL	POWER (P <sub>2</sub> )			PERFORMANCE	
	Three-phase	kW	HP ▲	Q l/min	H metres
F4-32/160B	0.37	0.5	IE2	50 – 200	7.5 – 4.5
F4-32/160A	0.37	0.5		50 – 225	9 – 5
F4-32/200B	0.75	1	IE3	50 – 250	12.5 – 9
F4-32/200A	1.1	1.5		50 – 250	14 – 10.5
F4-32/200BH	0.75	1	IE3	50 – 150	11.3 – 9.2
F4-32/200AH	0.75	1		50 – 160	13.8 – 11
F4-32/250C	1.1	1.5	IE3	50 – 220	18.4 – 15
F4-32/250B	1.5	2		50 – 250	21.7 – 17.4
F4-32/250A	2.2	3		50 – 270	23.8 – 18.7
F4-40/160B	0.37	0.5	IE2	50 – 320	7.5 – 3.5
F4-40/160A	0.55	0.75		50 – 350	9 – 4.5
F4-40/200B	0.75	1	IE3	50 – 350	11.5 – 7
F4-40/200A	1.1	1.5		50 – 350	13.8 – 10
F4-40/250C	1.1	1.5	IE3	50 – 400	15.5 – 10
F4-40/250B	1.5	2		50 – 400	17.5 – 12
F4-40/250A	2.2	3		50 – 400	22 – 17
F4-50/125B	0.55	0.75	IE2	150 – 600	5 – 2
F4-50/125A	0.55	0.75		150 – 600	6 – 3
F4-50/160B	0.75	1	IE3	150 – 650	8 – 3.8
F4-50/160A	1.1	1.5		150 – 700	9.3 – 4.5
F4-50/200C	1.5	2	IE3	200 – 850	11 – 7.5
F4-50/200B	2.2	3		200 – 850	13 – 9.5
F4-50/200A	2.2	3	IE3	200 – 900	15 – 11.2
F4-50/200AR	3	4		200 – 900	17 – 13.2
F4-50/250D	1.1	1.5	IE3	150 – 650	12.5 – 5
F4-50/250C	1.5	2		150 – 700	14 – 5
F4-50/250B	2.2	3		150 – 700	18 – 10.5
F4-50/250A	2.2	3		150 – 700	20 – 13
F4-50/250AR	3	4		150 – 700	23.5 – 17

MODEL	POWER (P <sub>2</sub> )			PERFORMANCE	
	Three-phase	kW	HP ▲	Q l/min	H metres
F4-65/125B	0.75	1	IE3	300 – 1100	4.7 – 3
F4-65/125A	1.1	1.5		300 – 1200	5.7 – 4
F4-65/160C	1.1	1.5	IE3	300 – 1100	7.5 – 5.5
F4-65/160B	1.5	2		300 – 1200	9.1 – 5.7
F4-65/160A	2.2	3	IE3	300 – 1200	10.1 – 7
F4-65/200A	2.2	3		300 – 1250	12 – 8.5
F4-65/200AR	3	4	IE3	300 – 1300	14 – 10
F4-65/250B	4	5.5		200 – 1250	21.8 – 15.5
F4-65/250A	5.5	7.5	IE3	200 – 1300	23.5 – 17
F4-80/160D	1.5	2		300 – 2000	6.3 – 2.5
F4-80/160C	2.2	3	IE3	300 – 2000	7.5 – 3.8
F4-80/160B	2.2	3		300 – 2000	8.8 – 5
F4-80/160A	3	4	IE3	300 – 2000	10 – 6.2
F4-80/200B	4	5.5		300 – 1800	14 – 9
F4-80/200A	5.5	7.5	IE3	300 – 1900	15.5 – 10.5
F4-80/250B	5.5	7.5		300 – 1800	19.5 – 13.5
F4-80/250A	7.5	10	IE3	300 – 1950	22 – 15
F4-100/160B	2.2	3		400 – 2600	8.3 – 3.5
F4-100/160A	3	4	IE3	400 – 2800	10 – 4.7
F4-100/200C	4	5.5		400 – 2300	12.7 – 7
F4-100/200B	5.5	7.5	IE3	400 – 2400	14.2 – 8.5
F4-100/200A	5.5	7.5		400 – 2600	15.8 – 9.5
F4-100/250B	7.5	10	IE3	400 – 2600	18.5 – 11.5
F4-100/250A	9.2	12.5		400 – 2900	22 – 13.5

Q = Flow rate

H = Total manometric head

Tolerance of characteristic curves in compliance with EN ISO 9906 Grade 3B.

▲ Three-phase motor efficiency class (IEC 60034-30-1)

# F4-100/160

## CHARACTERISTIC CURVES AND PERFORMANCE DATA

50 Hz n = 1450 min<sup>-1</sup> HS = 0 m

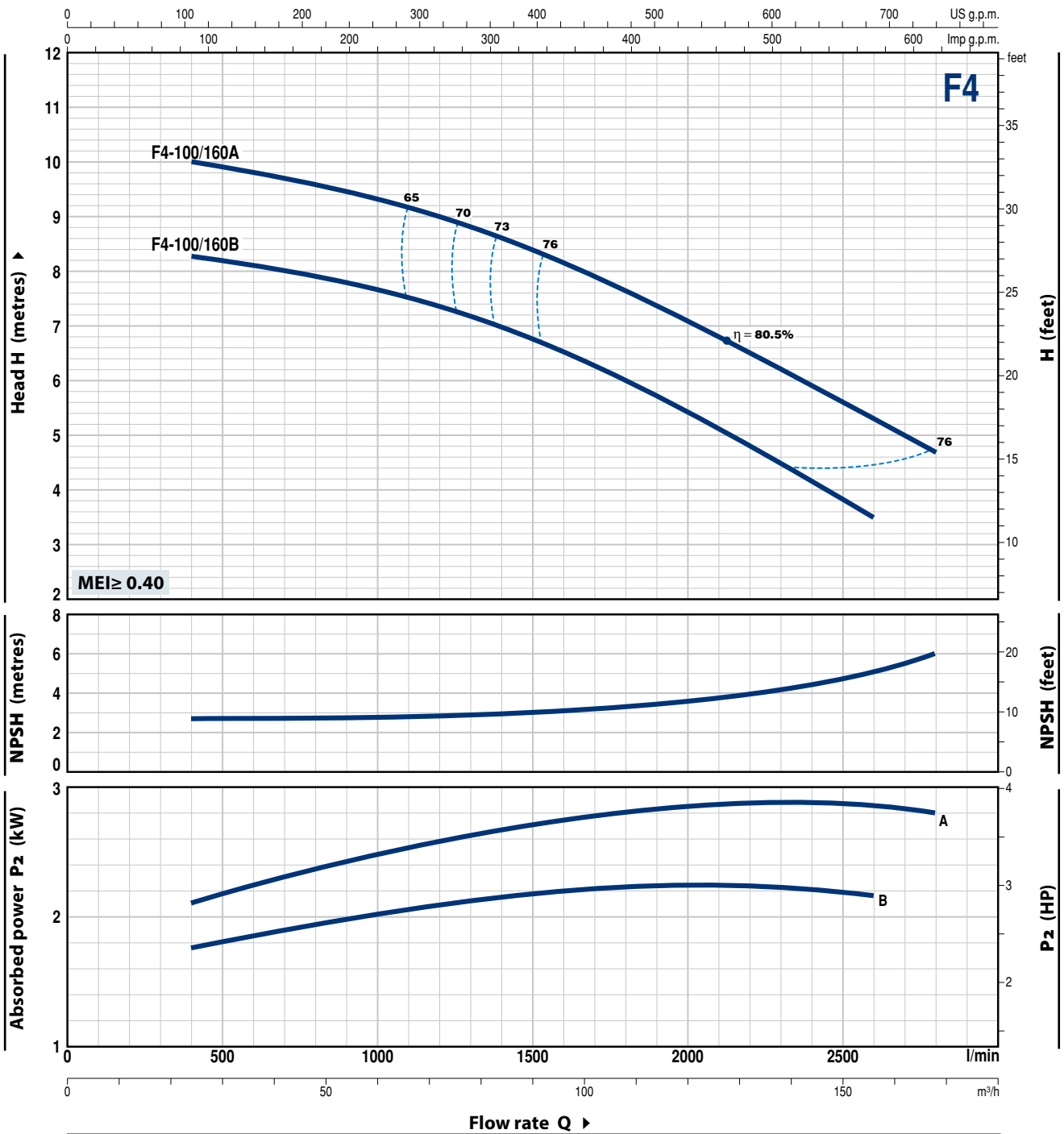

MODEL	POWER (P <sub>2</sub> )		Q	Flow rate										
	kW	HP		m <sup>3</sup> /h	24	48	72	96	120	144	156	168		
Three-phase			l/min	400	800	1200	1600	2000	2400	2600	2800			
F4-100/160B	2.2	3	H metres	8.3	8	7.5	6.5	5.5	4.2	3.5				
F4-100/160A	3	4		10	9.5	9	8	7	6	5.2	4.7			

Q = Flow rate H = Total manometric head HS = Suction height

Tolerance of characteristic curves in compliance with EN ISO 9906 Grade 3B.

## CHARACTERISTIC CURVES AND PERFORMANCE DATA

50 Hz n = 1450 min<sup>-1</sup> HS = 0 m

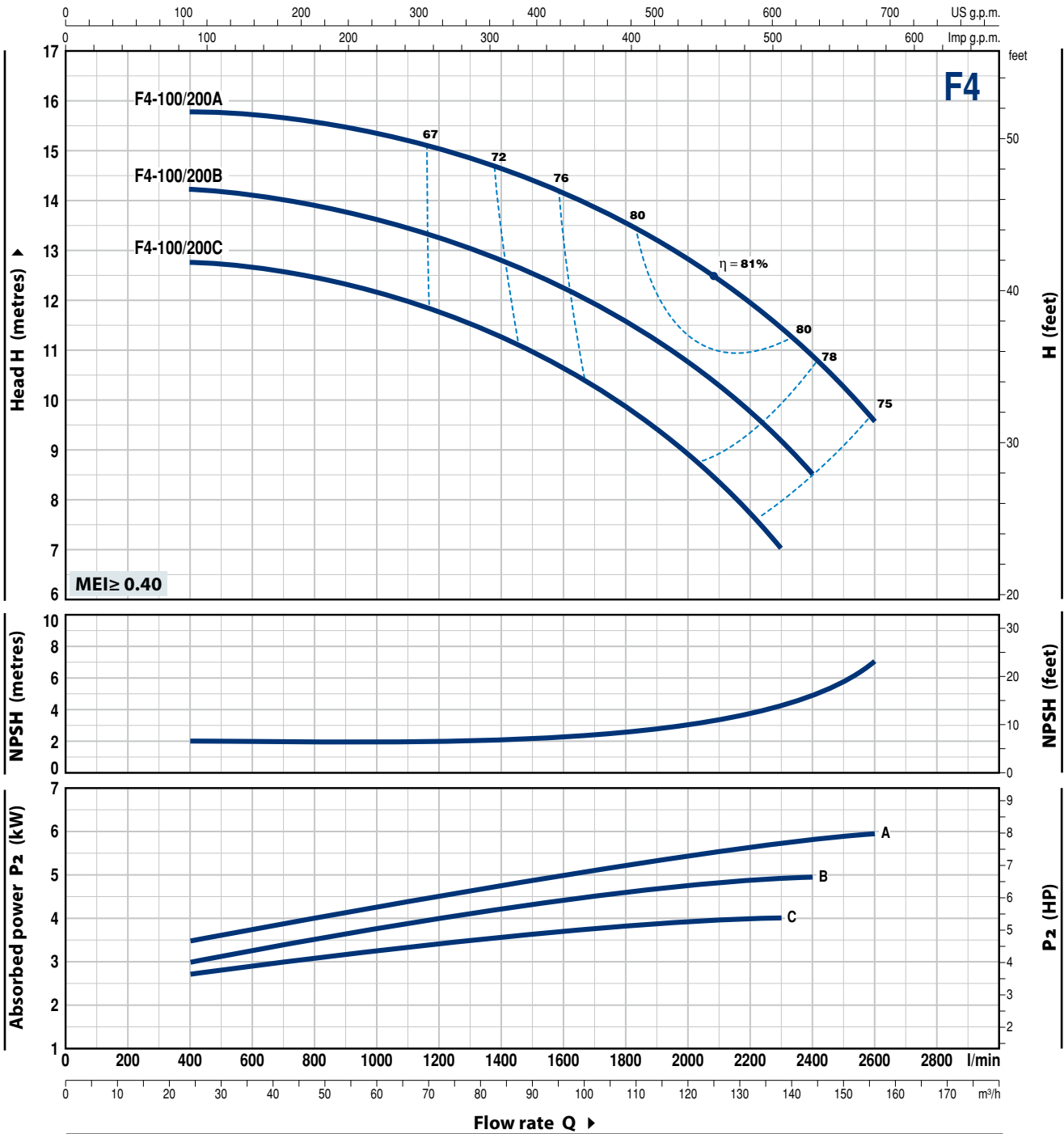

MODEL	POWER (P <sub>2</sub> )		Q	Flow rate													
	kW	HP		m <sup>3</sup> /h	24	36	48	60	72	84	96	108	120	138	144	156	
Three-phase			l/min	400	600	800	1000	1200	1400	1600	1800	2000	2300	2400	2600		
F4-100/200C	4	5.5	H metres	12.7	12.6	12.5	12.2	11.8	11.3	10.6	9.9	8.9	7				
F4-100/200B	5.5	7.5		14.2	14.1	13.9	13.6	13.3	12.8	12.2	11.6	10.7	9.2	8.5			
F4-100/200A	5.5	7.5		15.8	15.7	15.6	15.4	15	14.6	14.2	13.5	12.8	12	11.4	9.5		

Q = Flow rate H = Total manometric head HS = Suction height

Tolerance of characteristic curves in compliance with EN ISO 9906 Grade 3B.

# F4-100/250

## CHARACTERISTIC CURVES AND PERFORMANCE DATA

50 Hz n = 1450 min<sup>-1</sup> HS = 0 m

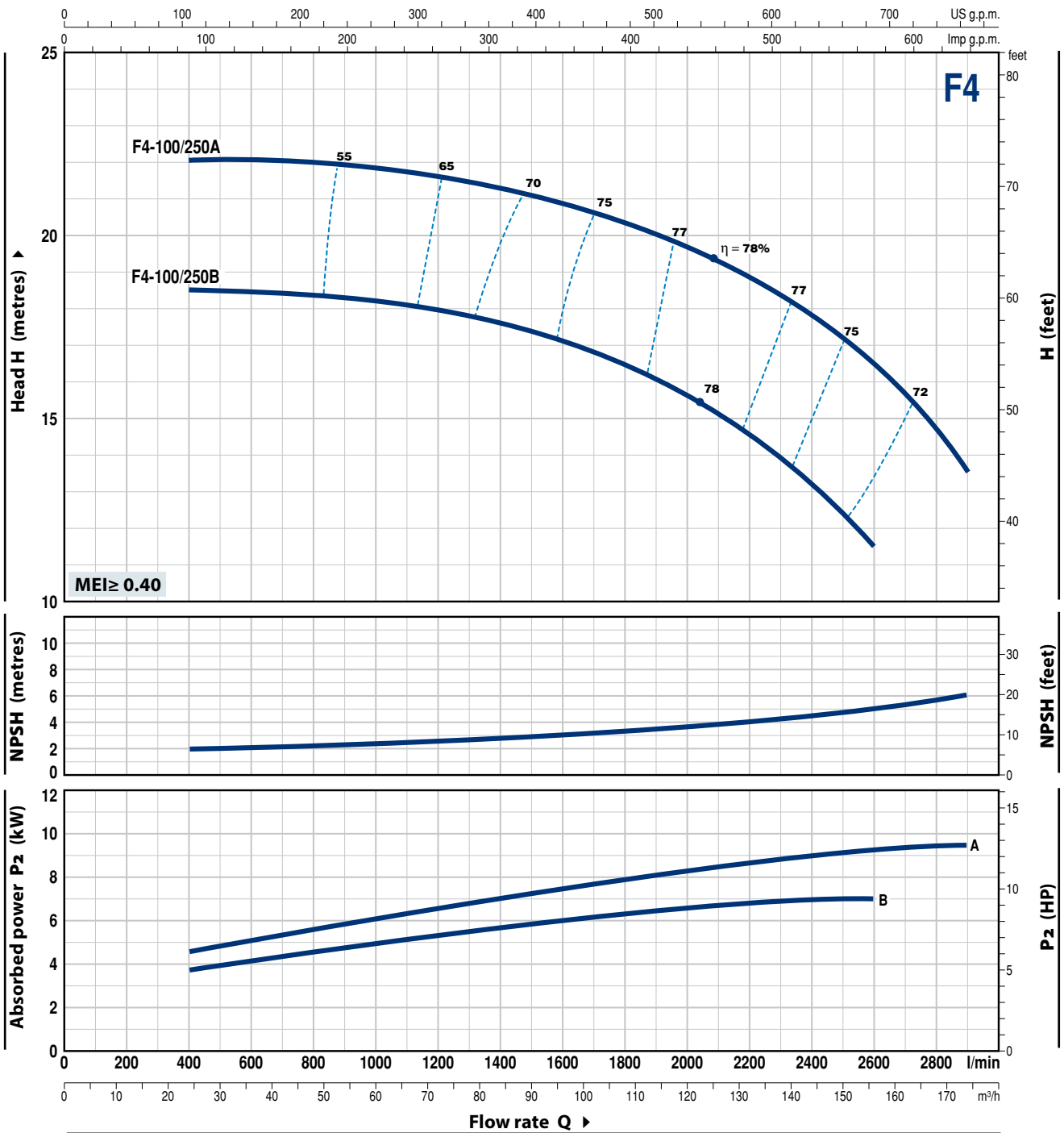

MODEL	POWER (P <sub>2</sub> )		Q	Flow rate														
	kW	HP		m <sup>3</sup> /h	24	36	48	60	72	84	96	108	120	132	144	156	174	
Three-phase			l/min	400	600	800	1000	1200	1400	1600	1800	2000	2200	2400	2600	2900		
F4-100/250B	7.5	10	H metres	18.5	18.5	18.3	18.2	18	17.5	17.1	16.5	15.7	14.5	13.2	11.5			
F4-100/250A	9.2	12.5		22	22	22	21.8	21.6	21.2	20.9	20.3	19.7	18.9	17.9	16.5	13.5		

Q = Flow rate H = Total manometric head HS = Suction height

Tolerance of characteristic curves in compliance with EN ISO 9906 Grade 3B.

## POS. COMPONENT CONSTRUCTION CHARACTERISTICS

<b>1 PUMP BODY</b>	Cast iron, complete with flanged suction and delivery ports					
<b>2 BODY BACKPLATE</b>	Cast iron					
<b>3 IMPELLER</b>	Brass for F4-32/160, 32/200, 40/160, 40/200, 50/125, 50/160					
<b>4 MOTOR SHAFT</b>	Stainless steel AISI 431					
<b>5 MECHANICAL SEAL</b>	<b>Pump Model</b>	<b>Seal Model</b>	<b>Shaft Diameter</b>	<b>Stationary ring</b>	<b>Rotational ring</b>	<b>Elastomer</b>
	F4-32/160 F4-40/160	F4-50/125	<b>FN-20</b>	<b>Ø 20 mm</b>	Graphite	Ceramic NBR
	F4-32/200 F4-40/200	F4-50/160 F4-65/125	<b>FN-24</b>	<b>Ø 24 mm</b>	Graphite	Ceramic NBR
	F4-50/200 F4-65/200 F4-65/160	F4-80/160 F4-100/160	<b>FN-32 NU</b>	<b>Ø 32 mm</b>	Graphite	Ceramic NBR
	F4-32/250 F4-40/250	F4-50/250	<b>FN-38</b>	<b>Ø 38 mm</b>	Graphite	Ceramic NBR
	F4-65/250 F4-80/200	F4-100/200	<b>FN-40 NU</b>	<b>Ø 40 mm</b>	Graphite	Ceramic NBR
	F4-80/250	F4-100/250	<b>FN-45 NU</b>	<b>Ø 45 mm</b>	Graphite	Ceramic NBR
<b>6 BEARINGS</b>	<b>Pump Model</b>	<b>Model</b>	<b>Pump Model</b>	<b>Model</b>		
	F4-32/160 F4-40/160 F4-50/125	<b>6206 ZZ-C3 / 6204 ZZ</b>	F4-32/250 F4-40/250 F4-50/200 F4-50/250 F4-65/160 F4-65/200 F4-80/160 F4-100/160	<b>6208 ZZ-C3 / 6206 ZZ-C3</b>		
	F4-32/200 F4-40/200 F4-50/160 F4-65/125	<b>6307 ZZ-C3 / 6206 ZZ-C3</b>	F4-65/250 F4-80/200 F4-80/250 F4-100/200 F4-100/250	<b>6310 ZZ-C3 / 6308 ZZ-C3</b>		
<b>7 ELECTRIC MOTOR</b>	<b>F4:</b> with 4 poles three-phase 230/400 V - 50 Hz ➔ <b>The three-phase pumps are fitted with high performance motors up to P<sub>2</sub>=0.37 kW in class IE2 and from P<sub>2</sub>=0.75 kW in class IE3 (IEC 60034-30-1)</b> – Insulation: class F – Protection: IP 55					

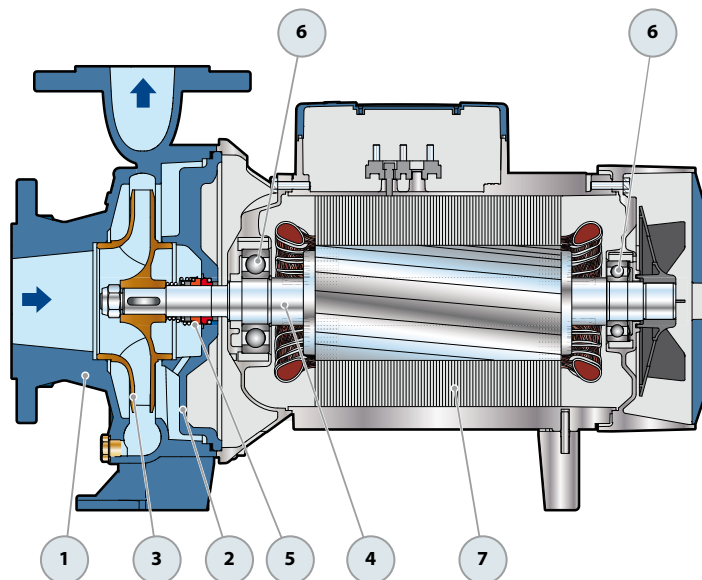

## DIMENSIONS AND WEIGHT

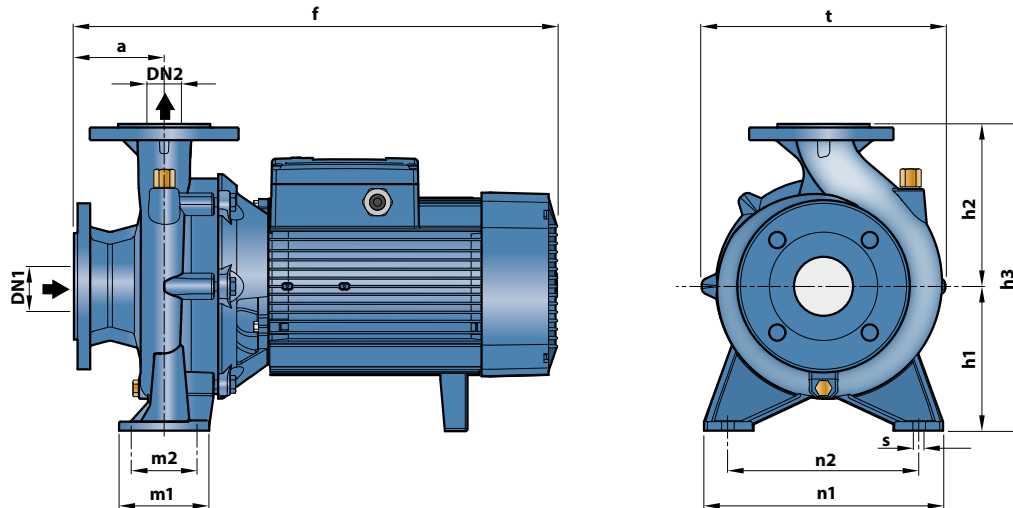

MODEL	DIMENSIONS mm													kg					
	DN1	DN2	a	f	h3	h1	h2	t	n2	n1	m1	m2	s						
<b>Three-phase</b>																			
F4-32/160B	50	32	80	412	292	132	160	242	190	240	100	70	14	31.2					
F4-32/160A																	31.2		
F4-32/200B																			43.4
F4-32/200A																			43.5
F4-32/200BH					100	469	340	160	180	270				95		42.3			
F4-32/200AH																42.4			
F4-32/250C							522	405	180	225	330	250		320	125	95	64.1		
F4-32/250B							568										63.1		
F4-32/250A													68.7						
F4-40/160B	65	40	80	412	292	132	160	240	190	240	100	70	14	32.5					
F4-40/160A																32.9			
F4-40/200B							489	340	160	180	275	212		265			46.0		
F4-40/200A																	46.2		
F4-40/250C					100	522	405	180	225	328	250	320		125	95	59.7			
F4-40/250B																60.1			
F4-40/250A							568										72.4		
F4-50/125B							431	292	132	160	242	190		240				32.2	
F4-50/125A														32.2					
F4-50/160B			100	489	340	160	180	269	212	265	100	70	14	44.4					
F4-50/160A																	44.6		
F4-50/200C					529			200			316						59.2		
F4-50/200B					576	360											68.3		
F4-50/200A													68.5						
F4-50/200AR													68.8						
F4-50/250D				522									59.9						
F4-50/250C													63.3						
F4-50/250B				568	405	180	225	337	250	320	125	95	68.7						
F4-50/250A													69.1						
F4-50/250AR													78.0						
F4-65/125B	80	65	100	511	340	160	180	291	212	280			14	50.2					
F4-65/125A																			50.4
F4-65/160C							533	360				200		300					55.0
F4-65/160B							579										125	95	58.7
F4-65/160A																	65.0		
F4-65/200A							582	405	180	225	340	250		320			72.0		
F4-65/200AR																	78.4		
F4-65/250B							627	450	200	250	373	280		360	160	120	18	111.2	
F4-65/250A													139.6						
F4-80/160D	100	80	125	565									14	65.8					
F4-80/160C																67.3			
F4-80/160B							611	405	180	225	330	250		320	125	95	70.0		
F4-80/160A																	76.4		
F4-80/200B							655	430		250	360	280		345			100.0		
F4-80/200A																	130.2		
F4-80/250B							673	480	200	280	405	315		400	160	120	18	149.5	
F4-80/250A																	137.6		
F4-100/160B	125	100	125	622				362	280	360			18	91.0					
F4-100/160A																		97.0	
F4-100/200C							657	480			200	280		391			160	120	116.0
F4-100/200B																			124.1
F4-100/200A					140	694				422	315	400				143.0			
F4-100/250B																		143.0	
F4-100/250A							789	505	225										159.3

## FLANGED PORTS

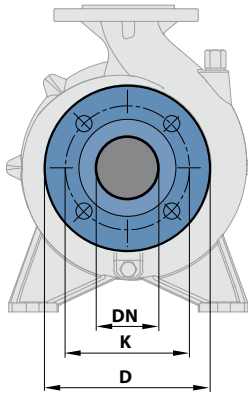

DN FLANGES mm	D mm	K mm	HOLES	
			N°	Ø (mm)
32	140	100	4	18
40	150	110		
50	165	125		
65	185	145		
80	200	160	8	
100	220	180		
125	250	210		

## COUNTER FLANGES

(CAN BE ORDERED SEPARATELY)

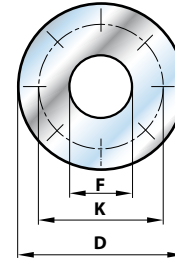

DN FLANGES mm	F COUNTERFLANGES	D mm	K mm	HOLES	
				N°	Ø (mm)
32	1¼"	140	100	4	18
40	1½"	150	110		
50	2"	165	125		
65	2½"	185	145		
80	3"	200	160	8	
100	4"	220	180		
125	5"	250	210		

## ABSORPTION

MODEL	VOLTAGE	
	230–240 V	400–415 V
<b>Three-phase</b>		
F4-32/160B	1.9 A	1.1 A
F4-32/160A	1.9 A	1.3 A
F4-32/200B	3.6 A	2.1 A
F4-32/200A	4.0 A	2.3 A
F4-32/200BH	3.3 A	1.9 A
F4-32/200AH	3.5 A	2.0 A
F4-32/250C	5.7 A	2.6 A
F4-32/250B	7.3 A	3.3 A
F4-32/250A	7.8 A	5.2 A
F4-40/160B	2.1 A	1.2 A
F4-40/160A	2.8 A	1.6 A
F4-40/200B	3.6 A	2.1 A
F4-40/200A	4.2 A	2.4 A
F4-40/250C	5.5 A	2.6 A
F4-40/250B	6.1 A	3.5 A
F4-40/250A	8.5 A	5.2 A
F4-50/125B	2.3 A	1.4 A
F4-50/125A	2.6 A	1.5 A
F4-50/160B	3.3 A	2.1 A
F4-50/160A	4.2 A	2.4 A
F4-50/200C	6.1 A	3.5 A
F4-50/200B	8.0 A	4.6 A
F4-50/200A	9.0 A	5.2 A
F4-50/200AR	10.6 A	6.8 A
F4-50/250D	4.9 A	2.8 A
F4-50/250C	5.9 A	3.4 A
F4-50/250B	8.5 A	4.9 A
F4-50/250A	9.9 A	5.7 A
F4-50/250AR	11.8 A	6.8 A

MODEL	VOLTAGE	
	230–240 V	400–415 V
<b>Three-phase</b>		
F4-65/125B	3.6 A	2.1 A
F4-65/125A	4.5 A	2.6 A
F4-65/160C	5.2 A	2.7 A
F4-65/160B	5.9 A	3.4 A
F4-65/160A	7.8 A	4.5 A
F4-65/200A	9.0 A	5.2 A
F4-65/200AR	11.8 A	6.8 A
F4-65/250B	17.3 A	9.5 A
F4-65/250A	21.7 A	13.5 A
F4-80/160D	5.9 A	3.4 A
F4-80/160C	8.1 A	4.7 A
F4-80/160B	9.2 A	5.3 A
F4-80/160A	10.6 A	6.8 A
F4-80/200B	13.8 A	9.5 A
F4-80/200A	18.2 A	12.8 A
F4-80/250B	20.8 A	13.5 A
F4-80/250A	25.6 A	14.8 A
F4-100/160B	9.0 A	5.2 A
F4-100/160A	11.2 A	6.5 A
F4-100/200C	14.2 A	9.5 A
F4-100/200B	17.8 A	12.1 A
F4-100/200A	20.8 A	13.5 A
F4-100/250B	26.8 A	15.9 A
F4-100/250A	34.1 A	19.7 A